

OPERATION MANUAL



METAL DUST COLLECTOR

Model. DCM-202

Order Code W321

Edition No : DCM-202-1

Date of Issue : 08/2020

MACHINE DETAILS

MACHINE

METAL DUST COLLECTOR

MODEL NO.

DCM-202

SERIAL NO.

DATE OF MANF.

DISTRIBUTED BY



www.machineryhouse.com.au

www.machineryhouse.co.nz

NOTE:

This manual is only for your reference. Owing to the continuous improvement of the HAFCO METALMASTER machine, changes may be made at any time without obligation or notice. Please ensure the local voltage is the same as that listed on the specification plate before operating this electric machine.



NOTE:

In order to see the type and model of the machine, please see the specification plate. Usually found on the back of the machine. See example (Fig.1)

An example of a product specification plate for a HAFCO machine. It features the HAFCO logo at the top, followed by the text "PRODUCT SPECIFICATION". Below this, there are seven rows, each with a label and a corresponding empty rectangular box for data entry: MODEL:, CAPACITY:, SER. NO., MFG DATE:, WEIGHT:, VOLTS:, and MOTOR Kw:. At the bottom of the plate, the website www.machineryhouse.com.au and "Made in China" are printed.

FIG.1

CONTENTS

1. GENERAL MACHINE INFORMATION	
1.1 Specifications.....	4
1.2 Included Accessories.....	4
1.3 Identification.....	5
2. SAFETY	
2.1 General Woodworking Machine Safety.....	6
2.2 Specific Safety For Dust Collectors.....	9
3. POWER SUPPLY	
3.1 Electrical Installation.....	10
3.2 Full Load Current.....	10
4. SETUP	
4.1 Unpacking.....	11
4.2 Clean Up.....	11
4.3 Site Preparation.....	11
4.4 Lifting Instructions.....	11
4.5 Assembly.....	12
5. OPERATION	
5.1 Operation Overview.....	13
5.2 Optional Accessories.....	13
6. MAINTENANCE	
6.1 Schedule.....	14
6.2 Cleaning The Motor Impeller.....	16
6.3 Cleaning The Ducting Hose.....	16
6.4 Cleaning or Replacing The Filters.....	17
6.5 Troubleshooting.....	18
Spare Parts.....	19
Risk Assessment Sheets.....	22

1.1 SPECIFICATION

Order Code	W321
MODEL	DCM-202
Dust Collector Type (Application)	Metal
Airflow (cfm)	650
Main Inlet Size (inch)	6
Adapter Inlets / Diameter (No/inch)	2/4
First-Stage Filter Type	Stainless Steel Mesh
Second-Stage Filter Type	Active Carbon
Second-Stage Filter Rating (Micron)	5
Third Stage Filter Type	Pleated Micro Filter
Third Stage Filter Rating (Micron)	1
Motor Power (hp)	1.5
Voltage (V/Hz)	240/50
Amps (A)	10
Dimensions (L x W x H) (mm)	725 x 508 x 1092
Weight (kg)	90.5

1.2 ACCESSORIES INCLUDED

- 4 x Casters
- 1 x Dust Port
- 1 x Y-Inlet
- 1 x Collection Drawer
- 1 x Pleated Micro Filter
- 1 x Active Carbon Filter
- 1 x Stainless-Steel Mesh Filter
- 1 x Dust Tray



1.3 IDENTIFICATION

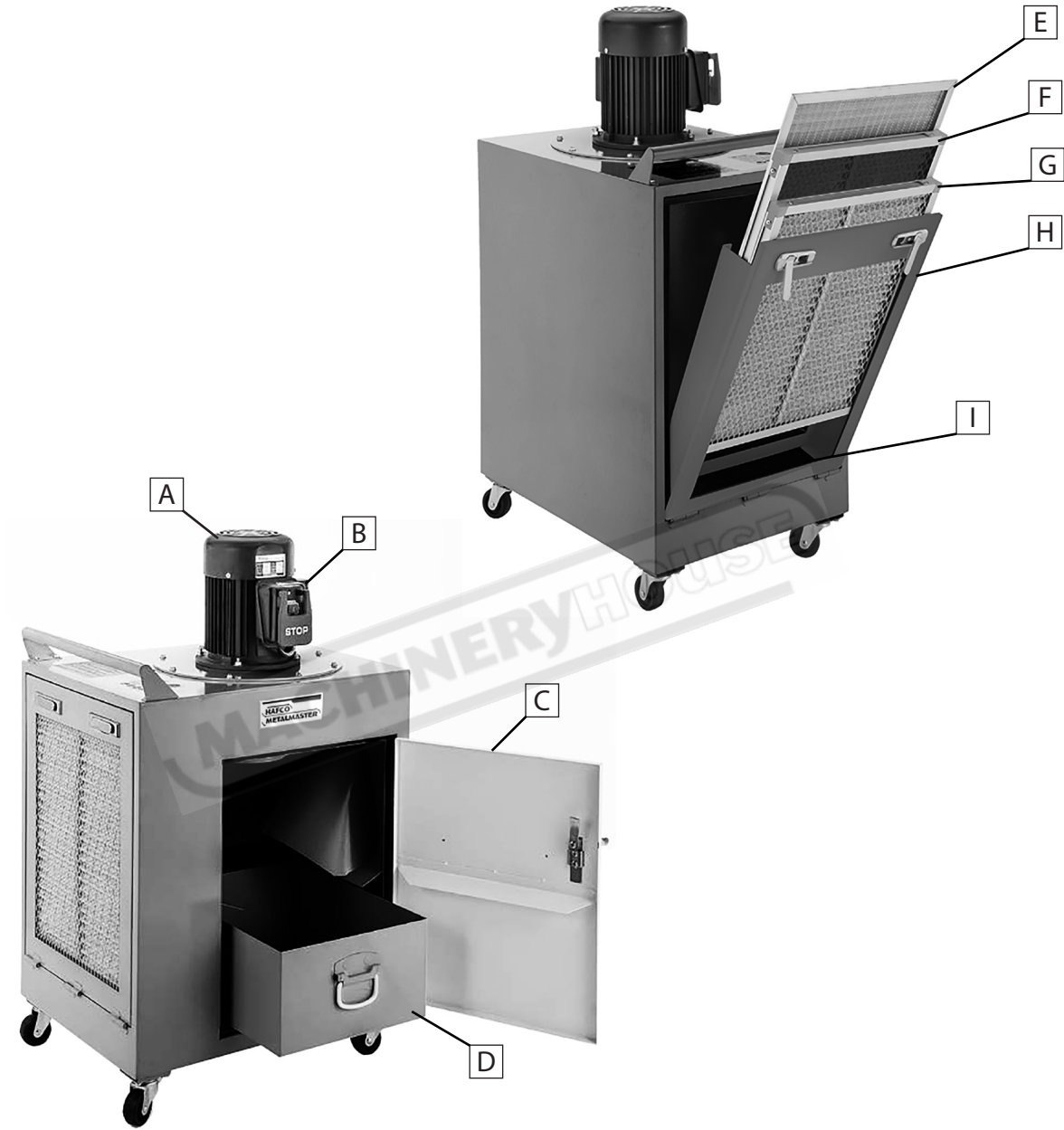

A	Motor	F	Active Carbon Filter
B	ON/OFF Switch with Paddle Stop	G	Pleated Micro Filter
C	Access Door	H	Filter Access Door
D	Collecting Door	I	Dust Tray
E	Stainless Steel Mesh Filter		

2.1 GENERAL METALWORKING MACHINE SAFETY

DO NOT use this machine unless you have read this manual or have been instructed in the use of this machine in its safe use and operation



WARNING

This manual provides safety instructions on the proper setup, operation, maintenance, and service of this machine. Save this manual, refer to it often, and use it to instruct other operators. Failure to read, understand and follow the instructions in this manual may result in fire or serious personal injury—including amputation, electrocution, or death.

The owner of this machine is solely responsible for its safe use. This responsibility includes, but is not limited to proper installation in a safe environment, personnel training and authorization to use, proper inspection and maintenance, manual availability and comprehension, of the application of the safety devices, integrity, and the use of personal protective equipment.

The manufacturer will not be held liable for injury or property damage from negligence, improper training, machine modifications or misuse.



- ✓ Always wear safety glasses or goggles.
- ✓ Wear appropriate safety footwear.
- ✓ Wear respiratory protection where required.
- ✓ Gloves should never be worn while operating the machine, and only worn when handling the work-piece.
- ✓ Wear hearing protection in areas > 85 dBA. If you have trouble hearing someone speak from one metre (three feet) away, the noise level from the machine may be hazardous.
- ✓ DISCONNECTION THE MACHINE FROM POWER when making adjustments or servicing.
- ✓ Check and adjust all safety devices before each job.
- ✓ Ensure that guards are in position and in good working condition before operating.
- ✓ Ensure that all stationary equipment is anchored securely to the floor.
- ✓ Ensure all machines have a start/stop button within easy reach of the operator.
- ✓ Each machine should have only one operator at a time. However, everyone should know how to stop the machine in an emergency.

2.1 GENERAL METALWORKING MACHINE SAFETY Cont.

- ✓ Ensure that keys and adjusting wrenches have been removed from the machine before turning on the power. Appropriate storage for tooling should be provided.
- ✓ Ensure that all cutting tools and blades are clean and sharp. They should be able to cut freely without being forced.
- ✓ Stop the machine before measuring, cleaning or making any adjustments.
- ✓ Wait until the machine has stopped running to clear cuttings with a vacuum, brush or rake.
- ✓ Keep hands away from the cutting head and all moving parts.
- ✓ Avoid awkward operations and hand positions. A sudden slip could cause the hand to move into the cutting tool or blade.
- ✓ Return all portable tooling to their proper storage place after use.
- ✓ Clean all tools after use.
- ✓ Keep work area clean. Floors should be level and have a non-slip surface.
- ✓ Use good lighting so that the work piece, cutting blades, and machine controls can be seen clearly. Position any shade lighting sources so that they do not cause any glare or reflections.
- ✓ Ensure there is enough room around the machine to do the job safely.
- ✓ Obtain first aid immediately for all injuries.
- ✓ Understand that the health and fire hazards can vary from material to material. Make sure all appropriate precautions are taken.
- ✓ Clean machines and the surrounding area when the operation is finished.
- ✓ Use proper lock out procedures when servicing or cleaning the machines or power tools.

DO NOT

- × Do not distract an operator. Horseplay can lead to injuries and should be strictly prohibited.
- × Do not wear loose clothing, gloves, necktie's, rings, bracelets or other jewellery that can be come entangled in moving parts. Confine long hair.
- × Do not handle cuttings by hand because they are very sharp. Do not free a stalled cutter without turning the power off first. Do not clean hands with cutting fluids.
- × Do not use rags or wear gloves near moving parts of machines.
- × Do not use compressed air to blow debris from machines or to clean dirt from clothes.
- × Do not force the machine. It will do the job safer and better at the rate for which it was designed.



BEFORE OPERATING ANY MACHINE, TAKE TIME TO READ AND UNDERSTAND ALL SAFETY SIGNS AND SYMBOLS. IF NOT UNDERSTOOD SEEK EXPLANATION FROM YOUR SUPERVISOR.

2.1 GENERAL METALWORKING MACHINE SAFETY Cont.

HAZARDS ASSOCIATED WITH MACHINES include, but are not limited to:

- Being struck by ejected parts of the machinery
- Being struck by material ejected from the machinery
- Contact or entanglement with the machinery
- Contact or entanglement with any material in motion

Health Hazards (other than physical injury caused by moving parts)

- Chemicals hazards that can irritate, burn, or pass through the skin
- Airborne items that can be inhaled, such as oil mist, metal fumes, solvents, and dust
- Heat, noise, and vibration
- Ionizing or non-ionizing radiation (X-ray, lasers, etc.)
- Biological contamination and waste
- Soft tissue injuries (for example, to the hands, arms, shoulders, back, or neck) resulting from repetitive motion, awkward posture, extended lifting, and pressure grip)

Other Hazards

- Slips and falls from and around machinery during maintenance
- Unstable equipment that is not secured against falling over
- Safe access to/from machines (access, egress)
- Fire or explosion
- Pressure injection injuries from the release of fluids and gases under high pressure
- Electrical Hazards, such as electrocution from faulty or ungrounded electrical components
- Environment in which the machine is used (in a machine shop, or in a work site)



MACHINES ARE SAFEGUARDED TO PROTECT THE OPERATOR FROM INJURY OR DEATH WITH THE PLACEMENT OF GUARDS. MACHINES MUST NOT BE OPERATED WITH THE GUARDS REMOVED OR DAMAGED.

2.2 SPECIFIC SAFETY FOR DUST COLLECTORS

DO NOT use this machine unless you have been instructed in its safe use and operation and have read and understood this manual



Safety glasses must be worn at all times in work areas



Approved respirator should be worn.



Gloves must not be worn when using this machine.



Sturdy footwear must be worn at all times in work areas



Close fitting/protective clothing must be worn



Rings and jewelry must not be worn.

USE FOR INTENDED PURPOSE.

This is a metal dust collector and is only designed to capture noncombustible or non-explosive metal particles. When using the dust collector only collect one type of metal/material at one time. DO NOT use to collect wood or wood products. DO NOT use it to collect lead, magnesium, niobium, tantalum, titanium, zirconium, hafnium, asbestos, crystalline silica, gypsum, or any other non-metal products. DO NOT use to capture welding fumes, gases, vapors, liquids, smoke, or ordinary combustible materials. DO NOT connect this dust collector to any machine using a coolant system.

TOXIC MATERIALS.

Care should be taken not to expose operators to certain types of metal dusts or fumes that can result in serious, potentially deadly health effects. To reduce this risk, investigate the toxicity of metal types you work with and always seek to minimize or eliminate exposure to the operator and other bystanders.

KNOW WHEN TO CHANGE FILTERS

A simple but important safety requirement is to change filters when airflow through the system reaches a reduced pressure. Filter changing is also necessary when the pressure drop across the collector is affecting the ability of the system to capture dust, allowing it to escape into the atmosphere. Some cartridge filters can operate longer between changes. However, for heavy dust-loading applications, filter replacement might be much more frequent.

RISK OF FIRE/EXPLOSIONS.

Only connect with smooth-walled, sheet-metal ducting, to minimize static electrical charge. DO NOT use PVC pipe. If using ducting, the system must be sealed and grounded. Fine metal dust particles can ignite, depending on material type and circumstances. Be educated and prepared to fight a combustible metal fire. Keep the dust collector away from pilot lights, open flames, or other ignition sources.

NEVER use near chemical fumes or within an enclosed spray booth.

3. POWER SUPPLY

3.1 ELECTRICAL INSTALLATION

Place the machine near an existing power source. Make sure all power cords are protected from traffic, material handling, moisture, chemicals, or other hazards. Make sure there is access to a means of disconnecting the power source. The electrical circuit must meet the requirements for 240V.

NOTE: The use of an extension cord is not recommended as it may decrease the life of electrical components on your machine.

ELECTRICAL REQUIREMENTS

Nominal Voltage.....	240V
Cycle.....	50 Hz
Phase.....	Single Phase
Power Supply Circuit.....	10 Amps
Full Load Current.....	6.7 Amps

(Full load current rating is also on the specification plate on the motor.)

3.2 FULL-LOAD CURRENT RATING

The full-load current rating is the amperage a machine draws when running at 100% of the output power. Where machines have more than one motor, the full load current is the amperage drawn by the largest motor or a total of all the motors and electrical devices that might operate at one time during normal operations.

Full-Load Current Rating for this machine at 240V is 6.7 Amps

It should be noted that the full-load current is not the maximum amount of amps that the machine will draw. If the machine is overloaded, it will draw additional amps beyond the full-load rating and if the machine is overloaded for a long period of time, damage, overheating, or fire may be caused to the motor and circuitry.

This is especially true if connected to an undersized circuit or a long extension lead. To reduce the risk of these hazards, avoid overloading the machine during operation and make sure it is connected to a power supply circuit that meets the requirements.



4 SETUP

4.1 UNPACKING

This machine was carefully packaged for safe transport. When unpacking, separate all enclosed items from packaging materials and inspect them for shipping damage. If items are damaged, please contact your distributor.

NOTE: Save all the packaging materials until you are completely satisfied with the machine and have resolved any issues with the distributor, or the shipping agent.

When unpacking, check the packing list to make sure that all parts shown are included. If any parts are missing or broken, please contact the your distributor.

4.2 CLEAN - UP

The unpainted surfaces of the machine have been coated with a waxy oil to protect them from corrosion during shipment. Remove the protective coating with a solvent cleaner or a citrus based degreaser.

Optimum performance from your machine will be achieved when you clean all moving parts or sliding contact surfaces that are coated with rust prevented products.

It is advised to avoid chlorine based solvents, such as acetone or brake parts cleaner, as they will damage painted surfaces and strip metal should they come in contact. Always follow the manufacturer's instructions when using any type of cleaning product.

4.3 SITE PREPARATION

When selecting the site for the machine, consider the largest size of workpiece that will be processed through the machine and provide enough space around the machine for operating the machine safely. Consideration should be given to the installation of auxiliary equipment. Leave enough space around the machine to open or remove doors/covers as required for the maintenance and service as described in this manual.

It is recommended that the machine is stable on the floor to prevent tipping or shifting. It also reduces vibration that may occur during operation.

4.4 LIFTING INSTRUCTIONS

**WARNING**

This machine is extremely heavy.

Serious personal injury may occur if safe moving methods are not followed. To be safe, you will need assistance and power equipment when moving the shipping crate and removing the machine from the crate.



On the day that the machine arrives, make sure that a forklift or lifting device, with sufficient capacity is available to unload the machine from the vehicle. Ensure access to the chosen site is clear and that doors and ceilings are sufficiently high and wide enough to receive the machine.

4.5 ASSEMBLY

The machine must be fully assembled before it can be operated. First clean any parts that are coated in rust preventative to ensure the assembly process can proceed smoothly.

To assemble the dust collector:

1. Attach the casters to the bottom of dust collector using the 5/16" x 1/2" hex. head bolts. (Fig.4.1)

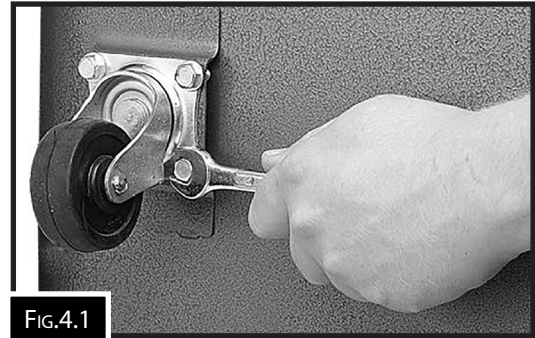

2. Attach the dust port to the side of the dust collector with the 5/16" x 1/2" button head cap screws. (Fig.4.2)

3. Using a Phillips screwdriver, attach the Y-inlet to the dust port with a #10 x 3/8" flange screw. (Fig.4.3).



4. Open the front access door. Remove the protective packing from the collecting drawer, and place the drawer into its place. (Fig.4.4) Close and lock the front access door.

4.5 ASSEMBLY Cont.

5. Open the filter door and make sure that the dust tray is installed correctly. (Fig.4.5)



FIG.4.5



FIG.4.6

6. Install the filters with the Pleated Micro filter on the outside, then the Active Carbon filter, in the middle and the Stainless Steel Mesh filter on the inside. (Fig.4.6)
Close and lock the filter access door and attach the dust collecting ducting to the dust port

USING CORRECT DUCTING

This dust collector is designed exclusively to collect dry metal, chips, and swarf. DO NOT use this dust collector to collect wood dust or metal chips containing cutting fluid or coolant. Due to fire or explosion risk, DO NOT use this machine to collect combustible or explosive metals such as, magnesium, niobium, tantalum, titanium, zirconium, hafnium, combustible liquids or fuels, gasoline, oil, or solvent-based paints.

For the best performance, place this dust collector as close to the dust-generating machines as possible and install dust shut off valves at the beginning of ducting lines. Only open one line at a time to focus the maximum suction from the machine where dust is being collected.

DUCTING MATERIAL

HAFCO METALMASTER DO NOT recommend using any plastic duct material with this machine. When plastic or non-conductive ducting is used, static electrical buildup in the ducting can cause explosion or fire hazard.

For the best results, use only Flame Retardant Dust Hose or smooth-wall, sheet-metal ducting or flexible metal ducting to connect to each machine.

Advantages of metal ducting is its conductivity and that it does not contribute to static electrical charge build-up.

5. OPERATION

5.1 OPERATING OVERVIEW

This machine may perform many types of operations that are beyond the scope of this manual. Many of these operations may be dangerous or deadly if performed incorrectly.

The instructions in this section are written with the understanding that the operator has the necessary knowledge and skills to operate this machine. If at any time you are experiencing difficulties performing any operation, stop using the machine!

If you are an inexperienced operator, we strongly recommend that you read books, trade articles, or seek training from an experienced operator before performing any unfamiliar operations. **Above all, your safety should come first!**

To use metal dust collector:

1. First turn the metal dust collector ON.
2. Turn dust-producing machine ON and perform the operation.
3. When shutting down first turn the dust-producing machine OFF when the operation is complete.
4. Turn metal dust collector OFF when finished with the operation and check or clean the collecting drawer. Empty drawer and tray when they are approximately 1/3–1/2 full.

5.2 OPTIONAL ACCESSORIES

DCH-100F - Flame Retardant Dust Hose 100mm x 4Mtrs.
(Order Code: W322A)

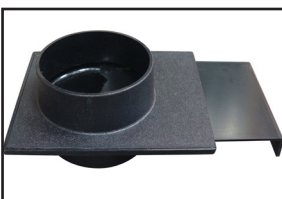

DCA-100C - Dust Hose Shut Off Valve 100mm
(Order Code: W335)



REPLACEMENT FILTERS

Stainless Steel Mesh Filter
1st Stage
(Order Code 3CP1025)



Active Carbon Filter
2nd Stage
(Order Code 3CP1024)

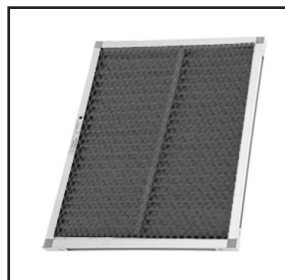

Pleated Micro Filter
3rd Stage
(Order Code 3CP1028)

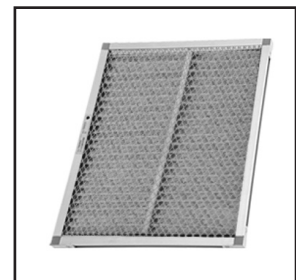

6. MAINTENANCE



WARNING

Before maintaining or cleaning the machine, turn off the circuit breaker, or disconnect the machine from the power supply.

Post a sign to inform other workers that the machine is under maintenance.

For optimum performance from the machine, it is important that the machine is well cleaned and maintain. Follow the maintenance schedule listed in the following section and refer to any specific instructions given.

6.1 SCHEDULE

To maintain a low risk of injury and proper machine operation, if you ever observe any of the items below, shut down the machine immediately and fix the problem before continuing operations:

- Loose mounting bolts.
- Check and empty dust collection drawer-and tray.
- Check or replace filters.
- Worn or damaged wires.
- Any other unsafe condition.

Weekly Check

- Clean dust buildup from inside cabinet and off motor. Inspect and clean inside ducts.

Every 10–15 Hours

- Clean Stage 1, 30-Micron stainless steel mesh filter.

Every 25–30 Hours

- Clean Stage 2, 5-Micron active carbon filter.

Every 35–40 Hours

- Clean Stage 3, 1-Micron pleated micro filter.

Every 300 Hours

- Replace 5-Micron active carbon filter and pleated micro filter every 300 hours or sooner if cleaning filters no longer improves airflow.

Frequently monitor and empty collection drawer and dust tray during operations.

When inspecting or emptying drawer or tray, always wear an approved respirator, approved safety goggles, and leather gloves.

6.2 CLEANING THE MOTOR IMPELLER

Normally the impeller requires no maintenance, but the blades can accumulate metal dust that can adversely affect impeller balance. Removing the motor and impeller assembly allows for cleaning and inspection of the impeller blades.

To clean impeller and inspect motor shaft:

1. DISCONNECT THE MACHINE FROM THE POWER!
2. Put on an approved respirator, approved safety goggles, and leather gloves.
3. Remove the 8 flange bolts from the motor mounting plate, that secures the motor and impeller assembly to the cabinet. (Fig. 6.1)
4. Remove motor/impeller assembly and carefully lay it on its side on the top of the cabinet.(Fig. 6.2)
5. Use a soft bristle brush and dry rag to remove the dust from the impeller blades and impeller housing. DO NOT use compressed air or your bare hands. Serious injury can occur if it enters the blood stream.
6. Inspect impeller for damage and replace if necessary
7. Replace motor and impeller and secure the flange bolts.

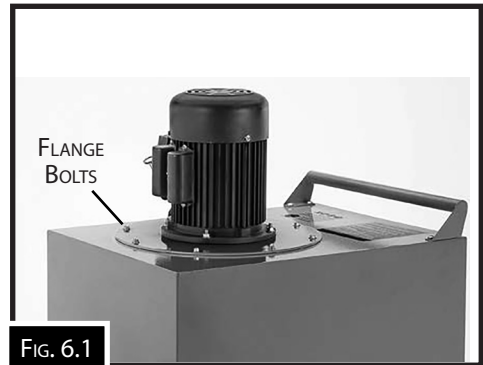

6.3 CLEANING THE DUCTING HOSE

Monthly inspection of all the ducts and fittings should be carried out and when required the ducts and fittings should be cleaned.

To clean inside the ducts:

1. DISCONNECT THE MACHINE FROM THE POWER SUPPLY!
2. Wear an approved respirator, approved goggles, and leather gloves.
3. Undo the clamps and disconnect the ducts and fittings. Use a soft bristle brush and dry or damp rag to remove the accumulated metal dust.
4. Reconnect the ducts and fittings and secure the clamps.

6.4 CLEANING OR REPLACING THE FILTERS

Cleaning and replacing filters is essential for the optimum operation of the dust collector. The 5-Micron active carbon and 1-Micron pleated micro filters need regular cleaning. Replace every 300 hours or when the airflow performance becomes noticeably reduced despite being cleaned.

Always clean filters outdoors where possible!

When cleaning filters, always inspect for damage and replace filters if ANY damage or tears are found.

NOTE: DO NOT use compressed air to clean filters, especially if indoors as it will likely cause a large amount of fine dust to become airborne and could damage the Stage-2 and -3 filters

Stage-1 Stainless-Steel Mesh Filter

Flush with water or other liquid into an enclosed container and air dry. Carefully collect flushed waste and dispose of properly.

Stage-2 Active Carbon Filter

Clean with a soft bristle brush and vacuum with a shop vacuum equipped with a HEPA filter.

Stage-3 Pleated Micro Filter

Clean with a soft bristle brush and vacuum with a shop vacuum equipped with a HEPA filter.

When Replacing Filters

1. DISCONNECT THE MACHINE FROM THE POWER!
2. Wear an approved respirator, approved goggles, and protective gloves while handling the filters.
3. Unlock the filter door and open to approximately 30 degrees.
4. Open the 2 retaining clips on the door and remove the filters (Fig. 6.3). If re-using the filters, note the airflow direction across filter for replacement in Step 5.
5. Replace the filters in same sequence shown with the stage 3 Pleated filter on the outside, then the stage 2 Active Carbon filter in the middle and the stage 1 Stainless Steel Mesh filter on the inside. Ensure the filters are installed with the proper airflow direction. Close retaining clips to secure filters.
6. Close and lock the filter door.



FIG. 6.3

6.5 TROUBLESHOOTING

Review the troubleshooting and procedures in this section if a problem develops with your machine. If you need replacement parts then follow the procedure in beginning of the spare parts section or if additional help with a procedure is required, then contact you distributor.

Note: Make sure you have the model of the machine, serial number, and manufacture date before calling.

Symptoms	Possible Cause	Possible Solution
Machine does not start or a breaker trips.	<ol style="list-style-type: none"> 1. Power supply circuit breaker tripped or fuse blown. 2. Motor wires connected incorrectly. 3. Plug/receptacle at fault/wired incorrectly. 4. Wiring open/has high resistance. 5. START/STOP or circuit breaker switch at fault. 6. Start capacitor at fault. 7. Centrifugal switch/contact points at fault. 8. Motor at fault. 	<ol style="list-style-type: none"> 1. Ensure circuit is sized correctly and free of shorts. Reset circuit breaker or replace fuse. 2. Correct motor wiring connections. 3. Test for good contacts; correct the wiring. 4. Check/fix broken, disconnected, or corroded wires. 5. Replace switch/circuit breaker. 6. Test/replace. 7. Adjust/replace centrifugal switch/contact points. 8. Test/repair/replace.
Machine has vibration or noisy operation.	<ol style="list-style-type: none"> 1. Debris caught in impeller. 2. Motor or component loose. 3. Motor fan rubbing on cover. 4. Motor mount loose/broken. 5. Motor bearings at fault. 6. Motor shaft bent. 7. Dust collector not on a flat surface. 8. Impeller damaged or unbalanced. 9. Impeller loose on motor shaft. 	<ol style="list-style-type: none"> 1. Inspect impeller for debris or damage. 2. Inspect/replace damaged bolts/nuts, and re-tighten with thread-locking fluid. 3. Fix/replace fan cover; replace loose/damaged fan. 4. Tighten/replace. 5. Test by rotating shaft; rotational grinding/loose shaft requires bearing replacement. 6. Test with dial indicator. Replace motor if damaged. 7. Stabilize dust collector. 8. Disconnect dust collector from power. Inspect impeller for dents, bends, or loose fins. Replace impeller if damaged. 9. Secure impeller; replace motor and impeller as a set if motor shaft and impeller hub are damaged
Dust collector does not adequately collect dust or chips; poor performance.	<ol style="list-style-type: none"> 1. Collection drawer or air filter dust tray are full. 2. Filters are dirty/clogged. 3. Clog in ducting. 4. Leak in ducting/connections. 5. Ducting blocked/restricted. 6. The dust collector is too far away from the point of suction, or there are too many sharp bends in the ducting. 7. Dust collector is undersized. 8. Run capacitor at fault. 9. Centrifugal switch/contact points at fault. 	<ol style="list-style-type: none"> 1. Empty collection drawer and dust tray. 2. Clean filters; replace with new filters if performance does not improve. 3. Remove clog. 4. Seal leak. 5. Remove ducting from dust collector inlet and unblock the restriction. 6. Relocate the dust collector closer to the point of suction; remove sharp bends in ducting. 7. Install a larger dust collector. 8. Test/replace. 9. Adjust/replace centrifugal switch/contact points if available.

SPARE PARTS SECTION

METAL DUST COLLECTOR

Model. DCM-202

Order Code W321

*Edition No : DCM-202-1**Date of Issue : 08/2020*

The following section covers the spare parts diagrams and lists that were current at the time this manual was originally printed. Due to continuous improvements of the machine, changes may be made at any time without notification.

HOW TO ORDER SPARE PARTS

1. Have your machines **model number, serial number & date of manufacture** on hand, these can be found on the specification plate mounted on the machine
2. A scanned copy of your parts list/diagram with required spare part/s identified.

NOTE: SOME PARTS MAY ONLY BE AVAILABLE AS AN ASSEMBLY

3. Go to www.machineryhouse.com.au/contactus and fill out the inquiry form attaching a copy of scanned parts list.

CONTENTS

Spare Parts Diagram.....	20
Spare Parts List.....	21

SPARE PARTS DIAGRAM

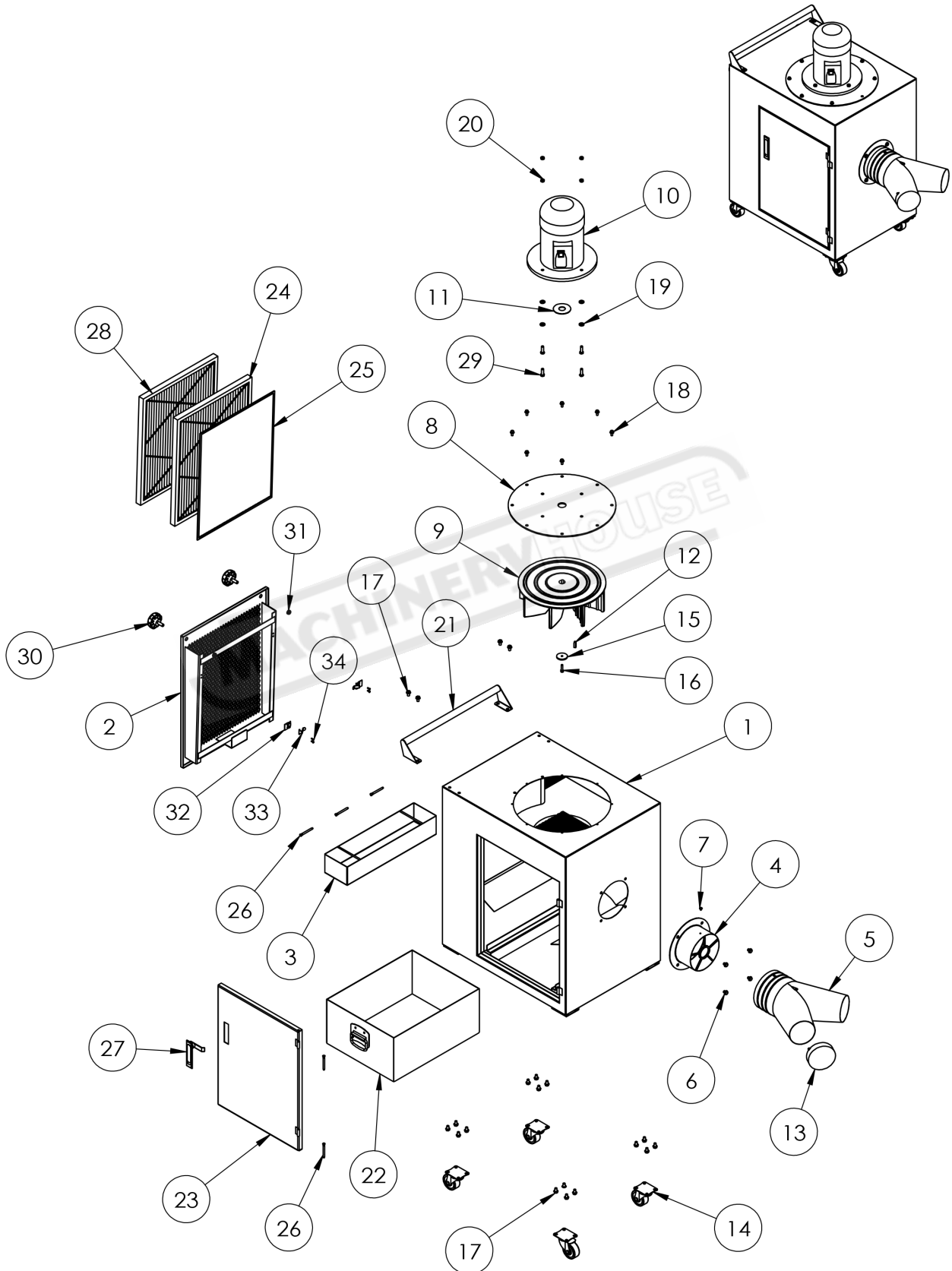

SPARE PARTS LIST

ITEM	DESCRIPTION	QTY.	ITEM	DESCRIPTION	QTY.
1	MAIN BODY	1	18	FLANGE BOLT 1/4" X 1/2"	8
2	SIDE DOOR	1	19	WASHER 5/16"	4
3	DUST TRAY	1	20	NUT 5/16"	4
4	INLET 6"	1	21	HANDLE	1
5	INLET ADAPTER 6" X 4" X 2	1	22	COLLECTION DRAWER	1
6	FLANGE BOLT 5/16" X 3/8"	4	23	DOOR	1
7	FLANGE SCREW 3/16 X 1/4"	1	24	ACTIVE CARBON FILTER	1
8	MOTOR PLATE	1	25	STAINLESS FILTER	1
9	IMPELLER	1	26	HINGE PIN	5
10	MOTOR	1	27	LATCH	1
11	MOTOR PACKING	1	28	PLEATED 1 MICRON FILTER	1
12	KEY 7 X 7 X 25	1	29	HEX BOLT 5/16" X 1	4
13	INLET ADAPTER CAP 4"	1	30	KNOB 3/8" X 1"	2
14	CASTER 2-1/2" SWIVEL	4	31	LOCK NUT 3/8"	2
15	IMPELLER WASHER	1	32	RETAINING CLIP	2
16	CAP SCREW M6 X 25	1	33	ADJUSTMENT BUCKLE	2
17	FLANGE BOLT 5/16" X 1/2"	20	34	TAB SCREW	4

NOTE: SOME INDIVIDUAL PARTS MAY ONLY BE AVAILABLE AS AN ASSEMBLY

WARNING

General Machinery Safety Instructions

Machinery House
requires you to read this entire Manual before using this machine.

- 1. Read the entire Manual before starting machinery.** Machinery may cause serious injury if not correctly used.
- 2. Always use correct hearing protection when operating machinery.** Machinery noise may cause permanent hearing damage.
- 3. Machinery must never be used when tired, or under the influence of drugs or alcohol.** When running machinery you must be alert at all times.
- 4. Wear correct Clothing.** At all times remove all loose clothing, necklaces, rings, jewelry, etc. Long hair must be contained in a hair net. Non-slip protective footwear must be worn.
- 5. Always wear correct respirators around fumes or dust when operating machinery.** Machinery fumes & dust can cause serious respiratory illness. Dust extractors must be used where applicable.
- 6. Always wear correct safety glasses.** When machining you must use the correct eye protection to prevent injuring your eyes.
- 7. Keep work clean and make sure you have good lighting.** Cluttered and dark shadows may cause accidents.
- 8. Personnel must be properly trained or well supervised when operating machinery.** Make sure you have clear and safe understanding of the machine you are operating.
- 9. Keep children and visitors away.** Make sure children and visitors are at a safe distance for you work area.
- 10. Keep your workshop childproof.** Use padlocks, Turn off master power switches and remove start switch keys.
- 11. Never leave machine unattended.** Turn power off and wait till machine has come to a complete stop before leaving the machine unattended.
- 12. Make a safe working environment.** Do not use machine in a damp, wet area, or where flammable or noxious fumes may exist.
- 13. Disconnect main power before service machine.** Make sure power switch is in the off position before re-connecting.
- 14. Use correct amperage extension cords.** Undersized extension cords overheat and lose power. Replace extension cords if they become damaged.
- 15. Keep machine well maintained.** Keep blades sharp and clean for best and safest performance. Follow instructions when lubricating and changing accessories.
- 16. Keep machine well guarded.** Make sure guards on machine are in place and are all working correctly.
- 17. Do not overreach.** Keep proper footing and balance at all times.
- 18. Secure workpiece.** Use clamps or a vice to hold the workpiece where practical. Keeping the workpiece secure will free up your hand to operate the machine and will protect hand from injury.
- 19. Check machine over before operating.** Check machine for damaged parts, loose bolts, Keys and wrenches left on machine and any other conditions that may effect the machines operation. Repair and replace damaged parts.
- 20. Use recommended accessories.** Refer to instruction manual or ask correct service officer when using accessories. The use of improper accessories may cause the risk of injury.
- 21. Do not force machinery.** Work at the speed and capacity at which the machine or accessory was designed.
- 22. Use correct lifting practice.** Always use the correct lifting methods when using machinery. Incorrect lifting methods can cause serious injury.
- 23. Lock mobile bases.** Make sure any mobile bases are locked before using machine.
- 24. Allergic reactions.** Certain metal shavings and cutting fluids may cause an allergic reaction in people and animals, especially when cutting as the fumes can be inhaled. Make sure you know what type of metal and cutting fluid you will be exposed to and how to avoid contamination.
- 25. Call for help.** If at any time you experience difficulties, stop the machine and call you nearest branch service department for help.

WARNING

Metal Dust Collector Safety Instructions

Machinery House
requires you to read this entire Manual before using this machine.

- 1. Maintenance.** Make sure the Dust collector is turned off and disconnect from the main power supply and make sure all moving parts have come to a complete stop before any inspection, adjustment or maintenance is carried out.
- 2. Dust collector Condition.** Dust collector must be maintained for a proper working condition. Never operate a Dust collector that has damaged or worn parts. Scheduled routine maintenance should be performed on a scheduled basis.
- 3. Inlet Hazard.** Do not place hands or tools near the open inlets during operation for any reason. The impeller could cause serious damage to body parts if touched while spinning.
- 4. Avoiding Entanglement.** Guards and dust bags must be used at all times. Remove loose clothing, belts, or jewelry items. Tie up long hair and use the correct hair nets to avoid any entanglement with the Dust collector.
- 5. Understand the machines controls.** Make sure you understand the use and operation of all controls.
- 6. Power outage.** In the event of a power failure during use of the Dust collector, turn off all switches to avoid possible sudden start up once power is restored.
- 7. Work area hazards.** Keep the area around the Dust collector clean from oil, tools, chips. Pay attention to other persons in the area and know what is going on around the area to ensure unintended accidents.
- 8. Hearing protection and hazards.** Always wear hearing protection as noise generated from dust collector can cause permanent hearing loss over time.
- 9. Dust Collector use.** This Dust Collector is designed to be used with Metal only. Do not pick up material that can not safely pass through the impeller.
- 10. Fire Hazard.** Ensure machines and hoses only connect with smooth-walled, sheet-metal ducting, to minimize static electrical charge. Ensure the dust extraction hose used is heat resistant and flame retardant and a minimum length of 2 meters between machine and dust collector. DO NOT use PVC pipe. If using ducting, the system must be sealed and grounded. Fine metal dust particles can ignite, depending on material type and circumstances. Be educated and prepared to fight a combustible metal fire. Keep the dust collector away from pilot lights, open flames, or other ignition sources. NEVER use near chemical fumes or within an enclosed spray booth.
- 11. Bags & guards.** All safety bags and guards must be used at all times. Bags must be replaced when damaged.
- 12. Emptying bags hazard.** Always wear a respirator and safety glasses when emptying dust into approved containers and dispose of properly.
- 13. Know When to Change Filters.** A simple but important safety requirement is to change filters when airflow through the system reaches a reduced pressure. Filter changing is also necessary when the pressure drop across the collector is affecting the ability of the system to capture dust, allowing it to escape into the atmosphere. Some cartridge filters can operate longer between changes. However, for heavy dust-loading applications, filter replacement might be much more frequent.
- 14. Toxic Materials.** Care should be taken not to expose operators to certain types of metal dusts or fumes that can result in serious, potentially deadly health effects. To reduce this risk, investigate the toxicity of metal types you work with and always seek to minimize or eliminate exposure to the operator and other bystanders.
- 15. Call for help.** If at any time you experience difficulties, stop the machine and call your nearest branch service department for help.

PLANT SAFETY PROGRAM

NEW MACHINERY HAZARD IDENTIFICATION, ASSESSMENT & CONTROL

Metal Dust Collector

Developed in Co-operation Between A.W.I.S.A and Australia Chamber of Manufactures

This program is based upon the Safe Work Australia, Code of Practice - Managing Risks of Plant in the Workplace (WHSA 2011 No10)

Item No.	Hazard Identification	Hazard Assessment	Risk Control Strategies <small>(Recommended for Purchase / Buyer / User)</small>
B	CRUSHING	LOW	Ensure dust collector is on level solid ground and in a safe place to avoid tipping.
C	CUTTING, STABBING, PUNCTURING	MEDIUM	Isolate power to machine prior to any checks or maintenance being carried out. Do not adjust or clean dust collector until fully stopped. Ensure hose remains fitted to prevent access to fan blade. Keep body parts away from moving parts.
H	ELECTRICAL	MEDIUM	All electrical enclosures should only be opened with a tool that is not to be kept with the machine. Only use smooth walled, sheet metal ducting to minimize electrical charge
M	HIGH TEMPERATURE or FIRE	MEDIUM	Ensure the dust extraction hose used is heat resistant and flame retardant and a minimum length of 2 meters between machine and dust collector Fine metal shavings can ignite, depending on material type and circumstances. Be educated and prepared to fight a combustible metal fire. Keep the dust collector away from pilot lights, open flames, or other ignition sources.
O	OTHER HAZARDS, NOISE.	LOW LOW LOW	Wear hearing protection as required. Approved respirator should be worn. Close fitting protective clothing should be worn.
Plant Safety Program to be read in conjunction with manufactures instructions			



www.machineryhouse.com.au



www.machineryhouse.co.nz

Authorised and signed by:
Safety officer:

Manager:

Revised Date: 11th August 2020